

Managing Mower Setup to Achieve Quality Putting Surfaces

Optimizing mower setup has a profound impact on the health and quality of putting greens.

BY BRIAN WHITLARK AND JOHN DANIELS

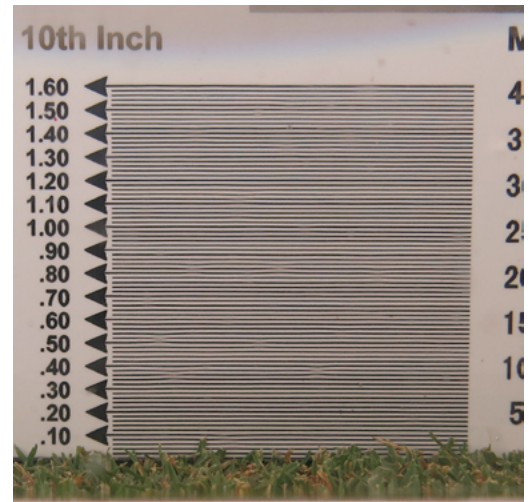

Sharp mowing equipment will produce a cleaner surface with fewer uncut leaf blades compared to mowers with dull reel blades and bedknives. Source: Brian Whitlark.

Golf courses, by and large, are judged based on the condition of their putting greens. Every golfer enjoys putting on uniform surfaces that roll true. A dense, healthy stand of turfgrass that is smooth and consistent should be the goal for all golf facilities, regardless of budget. Some may think that golf courses operating on a shoestring budget do not have the resources to produce and maintain quality putting surfaces; this is not necessarily true. All golf courses can maintain smooth surfaces for golfers to enjoy when the agronomic staff makes a commitment to quality. Part of that commitment is recognizing that equipment setup can have a significant impact on the most fundamental practice of maintaining quality putting surfaces — proper mowing.

Why is it important to consistently mow with properly calibrated, sharp equipment?

The one agronomic practice performed on putting greens with the greatest

frequency is mowing. Maintaining sharp, precisely adjusted putting green mowers is essential to produce quality putting surfaces. Whether your course is public or private, high budget or low budget, this principle should never be overlooked.

University research and numerous field observations have demonstrated the profound impact mowers have on turfgrass quality. In a 2004 study at Michigan State University, researchers concluded that “proper maintenance of the mowing equipment can have just as significant (if not more) of an impact on green speed as lowering the mowing height.”¹ Proper mower setup — i.e., sharp reels and bedknives with slight reel-to-bedknife contact — is critical to cleanly cut fine turf blades. Dull reel blades and bedknives will rip and tear leaf blades, leaving a white-to-brown appearance across a putting surface and leading not only to an unsightly appearance but also increasing turfgrass stress.

Sharp equipment improves turf health — Mowing with dull bedknives and reel blades leaves plants more vulnerable to attack from disease and insects than mowing with sharp blades. A study completed at Iowa State University demonstrated that sharp mowers with slight reel-to-bedknife contact on bentgrass yielded better visual quality, greater chlorophyll content, fewer shredded leaves, and less ethylene content — a measure of plant injury — when compared to bentgrass mowed with dull mowers.²

Sharp equipment leads to smoother greens — Often, numerous uncut leaves can easily be detected using a prism gauge or hand lens after mowing with dull equipment. Leaving uncut leaves is problematic, as an uneven cut leads to a bumpy putting surface.

Sharp equipment is more fuel efficient — A study conducted at the Bridgewater College in Cannington, England, sought to measure the fuel consumption of sharp and dull mowers

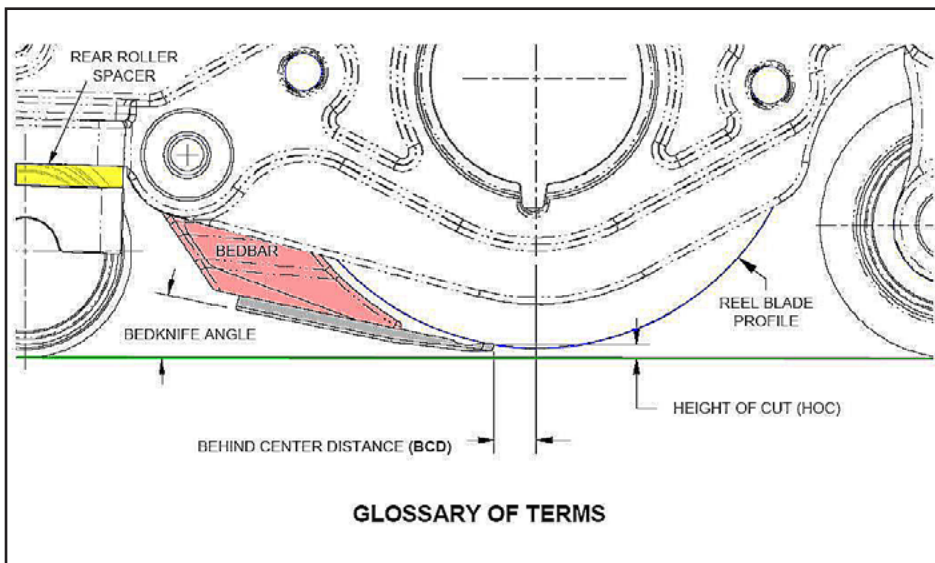

These are the mower characteristics that superintendents and equipment managers should be familiar with when optimizing mower setup for quality putting surfaces. Source: Toro.

and compare light reel-to-bedknife contact with no reel-to-bedknife contact. Four identical walking green mowers were set up with either dull — i.e., used for 30 days before the study and not sharpened — or sharp reel and bedknife and either no reel-to-bedknife contact — i.e., a 0.002-inch clearance between the reel and bedknife — or light reel-to-bedknife contact, described in the study as creating noise “slightly more than a whisper.” The dull mower setup with reel-to-bedknife contact used the most fuel. Surprisingly, the dull mower with no reel-to-bedknife contact consumed the second greatest volume of fuel. The difference between the sharp mowers with or without reel-to-bedknife contact was not great enough to be statistically significant; however, the sharp mower with no reel-to-bedknife contact appeared to use slightly less fuel. The take-home message from this study is that the most important characteristic in regard to reducing fuel consumption and emissions was the sharpness of the reels and bedknives.

How do you make sure mowers are sharp?

When a reel blade passes the bedknife it should be able to easily cut a single sheet of 20-pound office paper. There are a variety of methods used to produce sharp reels and bedknives, but it

is critical that green mowers cut paper across the entire width of the reel every time they leave the maintenance facility. A discussion on the pros and cons of the various grinding strategies is outside the scope of this article; however, it is important to note that every operation should be flexible and consider a variety of strategies to maintain sharp reels and bedknives.

For guidance on whether to maintain relief on reel blades, consult with your mower manufacturer. Mower manufacturers typically recommend that the reel blades be maintained with a 20- to 40-degree relief angle. Maintaining relief on reel blades reduces the width, or land area, of the blades and results in less metal contacting the turf, sand,

and bedknife; reduced mower fatigue; and reduced fuel consumption.

It also is important to maintain a top face angle on the bedknife of 3-6 degrees for green mowers to properly eject grass clippings into a basket and minimize the contact surface area with the reel blade. The front face angle — i.e., the presentation angle — should be maintained at 11-15 degrees to properly stand up turf blades before cutting.

Maintaining sharp edges on the bedknife and reel between heavy grindings is critical for consistency. Techniques such as front facing the bedknife and backlapping have fallen out of favor in some regions, but their benefits should not be discounted. Backlapping removes burrs and creates a honed edge that mates the reel and bedknife. As a guideline, if the mower will not cut paper after backlapping for 4-5 minutes, it is time for grinding.

An Arizona facility that had not utilized backlapping as a regular practice experimented with this technique as a means to reduce the frequency of grinding events while maintaining excellent quality of cut. After one year, the equipment manager and superintendent backlap daily and report longer service life for reels and bedknives.

What other mower characteristics do you need to monitor daily to be successful?

Height of Cut — The tolerance for error in height of cut should be no greater than 0.001 inch from one side



During the 2014 U.S. Senior Open Championship at Oak Tree National in Edmond, Oklahoma, Josh Cook, golf course superintendent, utilized a prism gauge to evaluate quality of cut and effective height of cut. Source: Brian Whittlark.

of the reel to the other. At today's low mowing heights, there is no room for error. Fortunately, there are several popular tools available that measure height of cut. The tools are outfitted with either an analog or digital dial indicator capable of measuring height of cut to one-thousandth of an inch. Height-of-cut gauges also may come with magnets that help hold the tool to the mower, reducing human error associated with applying pressure to the gauge during the measuring process. For a closer look at how to check the height of cut, watch [USGA Maintenance - 1/100ths - What Does 0.01 Mean?](#)

The height of cut set at the maintenance facility, also called the bench setting, is only part of the story. Effective height of cut, the actual mowing height in the field, is more relevant. The bench setting reveals little about the effective height of cut on a green, which can be determined with a prism gauge. There are numerous factors that influence effective height of cut:

- **Fixed-Head Versus Floating-Head Mowers** — Often, fixed-head mowers will cut at least 0.020 inch lower than floating-head mowers. The weight of the floating head mowers is dispersed among three rollers — the front and rear rollers on the cutting unit and the rear drive drum. The weight of fixed-head units is only spread across the front roller and the drive drum.

- **Bedknife Angle** — The more aggressive the mower setup (i.e., the steeper the angle of the bedknife and the greater the distance of the bedknife behind the center point of the reel), the lower it will mow. When switching from a less-aggressive to a more-aggressive bed bar — aka bed-shoe or bottom blade — the bench height of cut should be set approximately 0.015 to 0.025 inch higher to achieve the same effective height of cut.

- **Front roller style** — Smooth front rollers, even when weighted, will cut less grass than a lightweight, grooved front roller.³ Additionally, a small-diameter front roller penetrates deeper into the turf than a large-diameter roller and yields a lower

effective height of cut. For example, a 2-inch-diameter front roller, which often accompanies a fixed-head unit, will cause a lower effective height of cut than a larger, 2.5-inch-diameter front roller that is typically offered on floating-head mowers.

- **Frequency of Clip** — The frequency of clip can vary significantly among mowers and may influence the effective height of cut. The frequency of clip will be discussed in greater detail later in this article.

- **Weight of Attachments** — Increasing the number of blades per reel not only increases frequency of clip but also increases reel weight. A mower with a 14- or 15-blade reel — i.e., a heavier reel — often will cut 0.010 inch lower than a mower with an 11-blade reel.⁴ Grooming or brush attachments add weight to mowers and will contribute to lower effective height of cut. Often, it is suggested to set the bench height of cut 0.010 inch higher when outfitting a mower with a brush or groomer.

- **Bedknife Length** — An extended bedknife decreases mower aggressiveness and effective height of cut. The length of an extended bedknife — i.e., the distance from the back edge of the bedknife to the cutting edge — can be as much as 0.200 inch longer than a standard bedknife. For example, the behind-center distance of a bedknife on a mower set up at a 0.118 inch height of cut might be 0.393 inch and the distance from the reel blades to the bottom of the rollers or bench is only 0.087 inch — 0.031 inch closer to the bench than the top of the bedknife. When using an extended bedknife at the same height of cut, the behind-center distance *decreases* from 0.393 to 0.197 inch and the distance from the reel blades to the bench *increases* from 0.087 to 0.110 inch, nearly the same distance as the top of the bedknife, 0.118 inch.

- **Reel Diameter** — A mower with a new reel will cut up to 0.020 inch lower than a mower with a worn reel.

Standard And Extended Bedknife

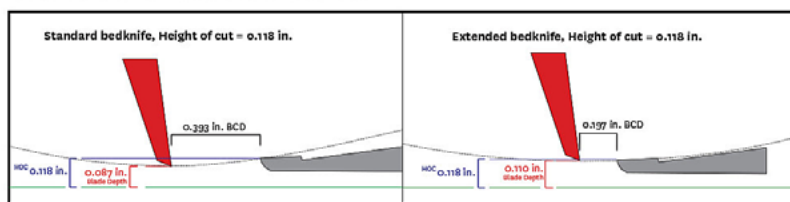

Utilize an extended bedknife to reduce the aggressiveness of a mower. In this case, an extended bedknife reduces BCD from 0.393 to 0.197 inch at a mowing height of 0.118 inch. Consequently, the reel blade depth into the canopy is raised by 26 percent, from 0.087 inch up to 0.110 inch. Source: Baroness.

Influence By Reels Of Different Diameter

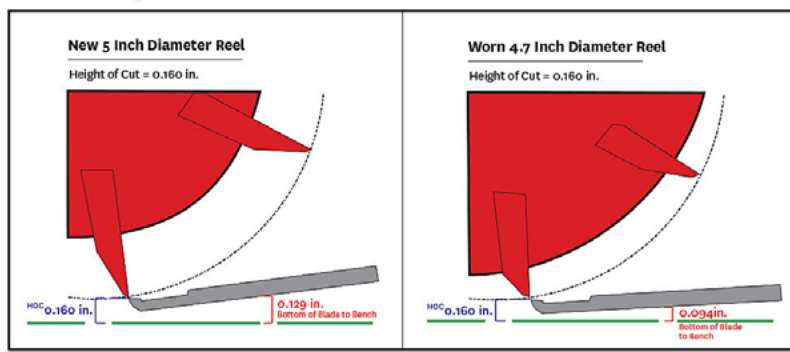

When reel diameter decreases from 5 to 4.7 inches as it wears, mower aggressiveness decreases. Notice that the distance from the bottom of the bedknife to the ground (bench) decreases from 0.129 inch with a new reel to 0.094 inch with a worn reel. Source: Baroness.

As the reel diameter decreases with normal wear and sharpening, the angle of the bedknife decreases to remain in contact with the reel. As the angle of the bedknife decreases, the effective height of cut will increase over time.

- **Operators** — The pressure of an operator's hands can increase the effective height of cut, especially when using fixed-head mower with a lightweight front roller or when mowing up slopes. The frequency at which an operator empties the grass clipping-collecting basket also can have a significant impact on effective height of cut.
- **Putting Green** — Site characteristics such as the amount of topdressing, thatch, moisture, turf density, and undulations all influence effective height of cut.

Although this list is not all-inclusive, it clearly shows that there is more to consider than just bench setting. Therefore, it is important to avoid comparing the bench setting height of cut from one course to another.

Reel-to-Bedknife Contact

The proper distance between a bedknife and reel is debatable. Most manufacturers suggest a clearance of 0.0005 to 0.0020 inch between bedknife and reel blades — often referred to as light contact. A feeler gauge or strip of paper should be used to ensure uniform clearance across the width of the bedknife. No contact — i.e., greater than a 0.0030-inch clearance between reel blades and bedknife — is not suggested because it tends to shred and tear leaf blades as opposed to cutting them in a scissor-like fashion. In the previously mentioned study conducted at Iowa State University, a sharp mower with light contact produced turf with better visual quality, more chlorophyll content, less mower injury, and less ethylene production when compared to a sharp mower with no contact.⁵ Heavy reel-to-bedknife contact can result in rifling, whereby a wavy wear pattern develops on the reel and/or bedknife. Rifling ultimately requires grinding the reel and replacing the bedknife.

Reel Shape and Roller Bearings

Reel sharpness, height of cut, and bedknife-to-reel contact should be checked and adjusted before every mowing. Additional mower characteristics such as roller and reel parallelism and shape and the condition of roller and reel bearings should be periodically checked. A [cone-shaped reel](#) — i.e., when one end of the reel is a larger diameter than the other end of the reel — most often occurs when mowing following regular topdressing events. The helical shape of reel blades causes sand to be thrown to one side of the reel, creating inconsistent wear and eventually a cone-shaped or tapered reel. The trailing edge — i.e., the right side of the reel when viewed from the front — often wears three to four times faster than the leading edge — i.e., the left side — of the reel.

As a guideline, the front roller should not have more than 0.001 inch of “play” when measured with a height-of-cut gauge. A video demonstrating the “play” in a front roller is included here: [Measure “play” in front roller](#). For quality of cut and accurate grinding, the rollers must be parallel to the reel and the reel must be round. An excellent video describing the procedure used to adjust the parallelism of a green mower cutting unit at Four Seasons Resort and Club Dallas at Las Colinas in Irving, Texas, is included here: [Advanced Cutting Unit Leveling — Stephen Tucker](#).

The most important aspect of managing green mowers is to fully engage and commit to mowing with sharp, accurately adjusted equipment on a daily basis. To maintain precise, accurate height of cut and optimal mower performance, equipment technicians must check and adjust every mower before every use. John Foy, retired regional director of the Southeast Region, explains the daily mower maintenance routine at PGA National Resort & Spa in Palm Beach Gardens, Florida, in the *How It's Done* video, [Daily Maintenance for Reel Mowers](#).

Maintaining sharp mowing equipment and properly setting height of cut and reel-to-bedknife contact are

important concepts of a successful mower setup. Additional factors like mower aggressiveness, frequency of clip, and mowing technique also affect mower performance.

What is an aggressive mower setup?

An aggressive mower setting is created by positioning the bedknife further behind the center point of a reel — referred to as increasing the behind-center distance (BCD) — and increasing the bedknife angle in relation to the ground, causing the reel blades to dip deeper into the turf canopy. With an aggressive setting, reel blades are positioned below the top edge of the bedknife — i.e., typically 0.03 to 0.04 inch below the cutting point of the bedknife — so that they help collect grass blades and push them up against the bedknife for cutting. A nonaggressive, flatter-attitude setting is achieved when the bedknife is positioned very close to the center point of the reel — i.e., the BCD is short. With a nonaggressive setup, reel blades may only pass 0.008 inch or less below the top edge of the bedknife. Table 1 lists the BCD and bedknife angle settings of four commonly used mower manufacturers.

For example, an aggressive setting with a BCD of 0.4 inch and a 7-degree bedknife angle will effectively cut lower than a less-aggressive setting and, more important, may improve the cut quality, leaving less uncut leaf blades, according to reports from the field. To date, research data do not support that an aggressive setting will enhance turf quality or surface smoothness.⁶ Nonetheless, superintendents are encouraged to experiment with more aggressive mower setup on one or two greens for several months to evaluate the pros and cons. An aggressive mower also will increase the reflective appearance of the turf — i.e., striping. However, proceed with caution as an aggressive mower setup will have greater potential for scalping, especially during periods of peak turf growth.

There are several methods that can be used to modify mower aggressiveness:

- Change to a black bed bar on Toro® green mowers. At a cutting height

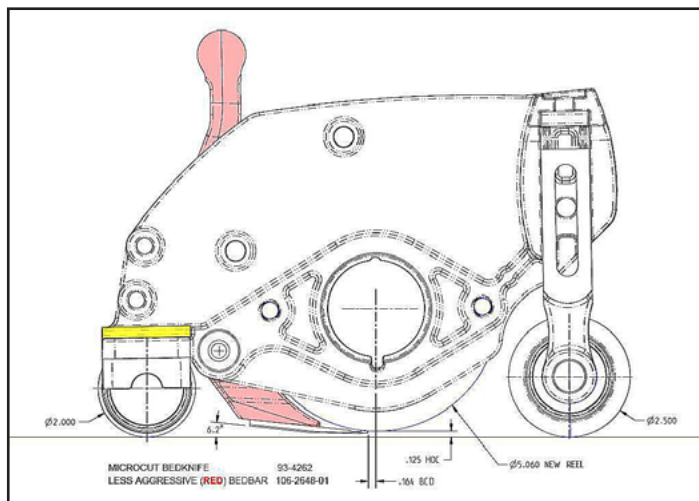
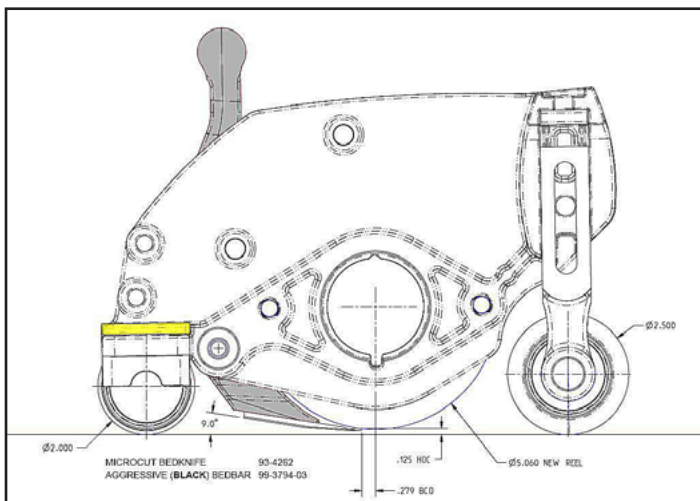

An aggressive bedbar on the left places the bedknife further behind center (0.279 inch) and at a steeper angle (9 degrees) when compared to a less aggressive bedbar on the right. The less-aggressive bedbar places the bedknife closer to the center point of the reel (0.164 inch) and at a shallower angle (6.2 degrees) compared to the more-aggressive bedbar. Source: Toro.

- of 0.125 inch, the BCD and bedknife angle when using a red bed bar are 0.164 inch and 6.2 degrees, respectively. At the same height of cut, a black bed bar increases the BCD to 0.279 inch and the bedknife angle to 9 degrees.
- Add a spacer to raise the rear roller on Toro® green mowers. Adding one spacer to shim up the rear roller increases BCD from 0.164 to 0.276 inch and bedknife angle from 6.2 to 8.8 degrees.
- Change to a black bed bar *and* raise the rear roller. Some superintendents have found that switching to a black bed bar and shimming up the rear roller offers the best quality of cut. Jay Willis, superintendent at Glen Eagle Golf Course in Millington, Tennessee, has used this strategy with great success on TifEagle bermudagrass greens.
- Simply raising or lowering the height of cut will change BCD. A good rule of thumb is that BCD will increase or decrease by half of the change in height of cut. For example, when the mowing height is *reduced* from 0.130 to 0.110 inch, BCD will *increase* — i.e., become more aggressive — by 0.010 inch. Conversely, raising the height of cut decreases BCD.
- A mower can be set up less aggressively by switching to an extended bedknife. For example, Baroness® offers two “offset” bedknives that decrease BCD from 0.393 inch

(standard) to either 0.295 or 0.197 inch.

- A mower with a worn reel will be less aggressive than a mower with a new reel. When a reel wears from 5 to 4.7 inches in diameter, the angle of the bedknife decreases by approximately 27 percent at 0.160 inch height of cut. Many new mowers on the market include bedknife adjustments to maintain mower aggressiveness throughout the life of the reel.

Will an aggressive mower setup collect less sand following topdressing than a nonaggressive setup?

Mowers quickly can become dull by picking up excessive amounts of sand following topdressing. Some superintendents feel that by switching to an aggressive setting, their mowers pick up less sand in the days immediately following topdressing. Subscribers to this theory describe nonaggressive

Table 1
Behind center distance (BCD) and bedknife attitude values from four commonly used mower manufacturers

Manufacturer	Behind Center Distance (inch)	Bedknife Attitude (degrees)
Toro*	0.164	6.2
Jacobsen**	0.140	7.3
Baroness***	0.393	9.0
John Deere****	0.096	1.1

*Red bedbar with Microcut Bedknife
 **Championship Bedknife
 ***Standard bedbar with 18G 1.5 Bedknife
 ****QA5 cutting unit with Low Cut Bedknife

Mower aggressiveness varies among manufacturers. These values are based on a 0.125-inch height of cut and the thinnest available bedknife from each respective manufacturer. It is important to note these values will change depending on the height of cut and bedknife selected. Source: Brian Whitlark and John Daniels.

setups as being analogous to a flat scoop shovel that slides along the putting green surface, easily picking up sand.

However, there also are reports of aggressive mowers picking up more sand than nonaggressive mowers following topdressing. Recently, Dr. Thomas Nikolai at Michigan State University and

Dr. John Sorochan at the University of Tennessee completed studies that show increasing BCD causes mowers to harvest more grass and more sand.⁷ In both studies, approximately 69 percent more sand was collected by an aggressive mower with a BCD of 0.393 inch when compared to a nonaggressive

mower with a BCD of 0.164 inch. Tom Langworthy, senior program manager with The Toro Company®, reports that a similar trend was observed in recent side-by-side trials of aggressive and nonaggressive mowers in Japan.⁸ Intuitively, this makes sense because as the bedknife is set more aggressively, reel blades dip deeper into the turf canopy and act like a vacuum brush that sweeps up sand particles at or near the surface.

In October 2015, a side-by-side study was conducted at three golf courses in the Phoenix, Arizona, area to test whether an aggressive mower setup would harvest more or less sand than a nonaggressive setup. At each course, fixed-head and floating-head mowers were outfitted with aggressive and nonaggressive bed bars. The mowers with an aggressive bed bar were set at a higher bench height of cut to match the effective height of cut

of the mowers with nonaggressive bed bars, as confirmed with a prism gauge. Sand topdressing was applied to the test greens and followed by light brushing and evening irrigation. The day following topdressing, an equal surface area was mowed with each mower setup. When the sand was separated from the clippings and

When considering mower setup changes, allow plenty of time to observe and evaluate the changes.

weighed, it was clear that the floating-head mower with an aggressive bed bar harvested more sand than the floating-head mower with a nonaggressive bed bar. However, interestingly, the fixed-head mower with an aggressive bed bar harvested less sand than the fixed-head mower with a nonaggressive bed bar. It is important to note that this study was not replicated; therefore, it was not practical to statistically evaluate the results.

Clearly, there are different and compelling arguments in support of both aggressive and nonaggressive mower setups. However, one point is clear — evaluating an aggressive or nonaggressive mower adjustment will require months, if not longer, to properly weigh the pros and cons of either setup. As such, when considering mower setup changes, superintendents — and the manufacturers offering mowers for demonstrations —

are encouraged to allow plenty of time to observe and evaluate the changes.

Does frequency of clip matter at low mowing heights?

The clip rate is defined as the forward travel distance between shear points. The shear point is the moment the reel blade passes the bedknife. Therefore, a shorter distance between shear points increases the frequency at which grass is clipped. To calculate frequency of clip, divide mower ground speed in inches per minute by the product of reel revolutions per minute (RPM) and the number of blades per reel.

Four mower factors influence frequency of clip:

- **Ground Speed** — The slower the ground speed of a mower, the less distance a mower will travel between shear points, resulting in a higher frequency of clip.
- **Reel Diameter** — If the number of blades per reel remains constant, a larger-diameter reel will have a lower frequency of clip than a smaller-diameter reel.
- **Reel Speed in RPM** — The faster a reel spins, the higher the frequency of clip.
- **Number of Blades Per Reel** — If ground speed remains constant, increasing the number of blades on a reel reduces the distance traveled between shear points, resulting in a higher frequency of clip.

Most manufacturers suggest that a frequency of clip equal to the height of cut is ideal. What remains unclear is how higher frequency of clip impacts putting green smoothness, green speed, and turf health. Some superintendents report that at higher frequency-of-clip rates, ball roll and green speed are similar to double cutting greens at lower frequency-of-clip rates. But does higher frequency of clip increase stress on turf? Some are of the opinion that reel blades will contact turf leaves multiple times before cutting at very high frequencies of clip, causing turf injury by stripping excessive tissue from leaf tips. However, the amount of research in this area is somewhat limited.



At very low effective mowing heights, use the thinnest bedknife available or grind the bedknife to a thinner thickness to provide enough clearance between the bottom of the bedknife and the ground. Source: Rodney Lingle.

One study conducted at Michigan State University in 2012 evaluated three different frequencies of clip — 0.100, 0.126, and 0.149 inch per clip — at three mowing heights. Over the course of three months on a creeping bentgrass green, no statistical differences were found in green speed, disease incidence, or clipping yield, although clipping yield was trending higher with the faster frequency of clip.⁹

In another study, Dr. Frank Rossi at Cornell University reported that a faster frequency of clip — i.e., 0.090 compared to 0.165 inch per clip — resulted in significantly lower turf quality ratings when averaged across four months due to higher incidence of anthracnose.¹⁰ Neither frequency of mowing — i.e., single or double mowing — nor frequency of clip — i.e., 0.090, 0.130, or 0.165 inch per clip — significantly increased green speed when mowers were set at 0.100-inch height of cut. However, cut cleanliness, as measured by the number of uncut leaves observed through a prism gauge, was significantly better at the 0.090-inch-per-clip frequency when compared to the slower frequencies of clip.

How can bedknife scalping be avoided?

At very low heights of cut, a mower may scalp as a result of the bedknife gouging the turf or reel blades being set too low into the canopy. The height at which a mower may scalp varies based on mower characteristics.

A guideline to help avoid bedknife gouging is to maintain at least 0.030 inches of clearance between the bottom of the bedknife and the effective height of cut.¹¹ For example, if a bedknife is 0.080 inch thick at the cutting point, the effective height of cut should be no less than 0.110 inch to avoid scalping. At very low effective heights of cut — e.g., 0.070 inch — the bedknife being used should be no thicker than 0.040 inch. Thus, many courses exclusively use the thinnest bedknife offered by manufacturers on greens mowers. At very low mowing heights, even the thinnest bedknives are ground to a thickness of 0.035 to 0.045 inch to avoid bedknife gouging.

How does double mowing impact putting green quality?

It is widely accepted that mowing multiple times will remove more grass. Double mowing also provides the ability

to cut leaf blades from multiple directions, which can limit the likelihood of developing grain. It is theorized that double mowing will increase shoot density and promote a more upright growth habit, thus improving surface smoothness. Many double mow to reduce the amount of uncut leaf blades left after mowing and increase green speed.

University research on the benefits of double mowing has been mixed. Work at Cornell University indicates that double mowing does not result in faster green speeds.¹² However, researchers at The Ohio State University found that double mowing significantly increased green speed, especially when double mowing with groomers.¹³ Work at Rutgers University showed a significant increase in ball roll distance and an occasional reduction in anthracnose severity when putting greens were double mowed versus single mowed.¹⁴ Likewise, researchers at Clemson University saw a 3-percent increase in green speed from double mowing when compared to single mowing.¹⁵

Through personal observation in the field, the second cut of a double mowing may lower the effective height

of cut by 0.005 to 0.010 inch. Multiple days of double mowing will further reduce the effective height of cut. During the 2015 U.S. Senior Open Championship at Del Paso Country Club in Sacramento, California, the effective height of cut was 0.100 inch before double mowing. After three days of double mowing, the effective height of cut reduced to 0.080 inch without changing the bench height of cut.

Superintendents are encouraged to experiment with double mowing on one green for extended periods — i.e., six to eight weeks — and compare green smoothness, green speed, effective height of cut, and turf stress to greens that received single mowing. A long-term evaluation is needed to determine if the additional labor and fuel required to double mow on a frequent basis is worth the improvement in putting green performance. To reduce labor costs, some superintendents who are adamant about the benefits of double mowing have switched to riding mowers for the second cut or exclusively use riding green mowers to accommodate double mow on a regular schedule. For more information on riding mowers and a comparison of their performance to the performance of walk-behind mowers, read the USGA *Green Section Record* article [Return of the Triplex](#).

How do you know if a modification to your mower setup is making a positive impact?

The information in this article is offered to encourage golf course superintendents in any region with any budget to engage in meaningful discussions with equipment managers to optimize

mower setup and ultimately improve the quality of putting surfaces. Experiment with fixed-head and floating-head mowers, set up your mowers more aggressively, try a higher frequency of clip on one or two greens, and allow a minimum of six to eight weeks to evaluate the results. Keep a prism gauge in your vehicle and use it regularly to evaluate the effective height of cut and quality of cut. Above all else, commit to consistently mowing with sharp, accurately adjusted equipment.

REFERENCES

- ¹Nikolai, T., L. D. McKinnon, and C. Johnson. 2005. 2004 green maintenance studies. p. [1-10]. In *Proceedings of the 75th Annual Michigan Turfgrass Conference*. East Lansing, Mich.: January 17-20, 2005. East Lansing, Mich.: Michigan State University.
- ²Howieson, M. J., and N. E. Christians. 2001. Mower settings, PGRs affect turfgrass quality: Regular mower maintenance results in visually appealing turfgrass. *Golf Course Manage.* 69(6):65-70.
- ³Personal communication, Dr. Thom Nikolai, Michigan State University.
- ⁴Personal communication, Rodney Lingle, Superintendent.
- ⁵Howieson, M. J., and N. E. Christians. 2001. Mower settings, PGRs affect turfgrass quality: Regular mower maintenance results in visually appealing turfgrass. *Golf Course Manage.* 69(6):65-70.
- ⁶Crop, Forage & Turfgrass Management: Posted 18 Sept. 2015; doi: 10.2134/cftm2015.0160.

⁷Crop, Forage & Turfgrass Management: Posted 18 Sept. 2015; doi: 10.2134/cftm2015.0160.

⁸Personal communication, Tom Langworthy, senior program manager with The Toro Company®.

⁹<http://archive.lib.msu.edu/tic/msufdf/article/2012g10.pdf> Personal communication, Dr. Thom Nikolai, Michigan State University.

¹⁰Personal communication, Dr. Frank S. Rossi, Department of Horticulture.

¹¹Personal communication, Rodney Lingle, Superintendent.

¹²Rossi, F. S. 2008. Does mower type effect turf performance. *CUTT.* 19(1):1, 6-8. <http://cutt.lib.msu.edu/article/2008one1.pdf>.

¹³Sweeney, Patty. 2000. *Factors Affecting Green Speed*. [7]. Ohio State University, Pennsylvania State University.

¹⁴Inguagiato, J. C., Murphy, J. A., and Clarke, B. B. (2009). Anthracnose disease and annual bluegrass putting green performance affected by mowing practices and lightweight rolling. *Crop science*, 49(4):1454-1462.

¹⁵McCullough, P. E., HH. Liu, and L. B. McCarty. (2005). Mowing operations influence creeping bentgrass putting green ball roll following plant growth regulator applications. *HortScience*, 40(2):471-474.

[Brian Whitlark](#) is an agronomist in the Southeast Region.

[John Daniels](#) is an agronomist in the Central Region.

SUBSCRIBE TO THE USGA GREEN SECTION RECORD

TEXT "GREENSECTION" TO "22828" OR [CLICK HERE](#)

Offering the latest information on golf course management, turfgrass culture, environmental issues, research and economic sustainability.