

Tool for Changing Cup

HARRY PRYKE, *Greenkeeper, Calgary Golf and Country Club, Calgary, Alberta*

The accompanying diagrams represent a simple three-in-one tool, easily made, which we have found much better for changing cups than the carrying around of a hammer, piece of pick handle, and hook separately.

The tool is a piece of 2" by 4", 1' 8" long, with a part of an old sledge hammer shaft thrust through one end and a hook bolted near the other end

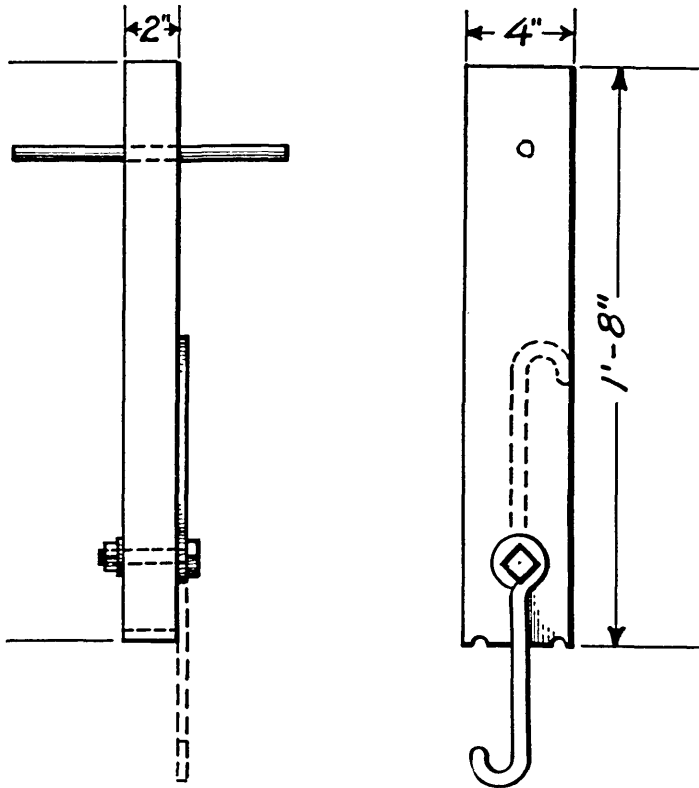

in such manner that it can be lowered for thrusting into the hole to lift the cup and folded back onto the block of wood when not in use for such purpose. The edges of the block at the hook end are chamfered so as to engage the rim of the cup when pressing it into the new hole. When the hook is folded back the block may be used for tamping the earth back into the hole.

SUBCOMMITTEES OF THE UNITED STATES GOLF ASSOCIATION,
 APPOINTED BY THE EXECUTIVE COMMITTEE FEBRUARY 9, 1923

RULES OF GOLF COMMITTEE—Howard F. Whitney, Chairman, No. 15 Broad St., New York City; James Francis Burke, Findlay S. Douglas, Robert A. Gardner, Cornelius S. Lee, Charles O. Pfeil, Wynant D. Vanderpool, George