

The Green Section's Stimpmeter: Most Think Friend - Some Think Enemy

by DONALD D. HOOS
Director, Western Region, USGA Green Section

TO AN ARCHEOLOGIST in the 25th century, this extruded aluminum bar, 36 inches long, with a v-shaped groove extending along its entire length, may well be a puzzle. But to us, it's a Stimpmeter! We use it to measure the speed of greens. It has a precisely milled ball-release notch 30 inches from the tapered end (the end that rests on the ground). It is simple enough. However, this simple device has been embroiled in controversy ever since it became available to golf course superintendents in 1978. Why the controversy?

Some opponents feel too much emphasis is being placed on green speed. As an example, one can point to the greatly publicized rebuilding of greens at the Augusta National Golf Club, in Augusta, Georgia. The objective of the rebuilding was to regain speed and uniformity that had diminished with the passage of time. The publicized average speed of greens at this year's Masters Tournament ranged from 11.32 feet to 11.61 feet, with an average of 11.48 feet. Fast by anyone's standards.

Prior to manufacture and release of the Stimpmeter to member clubs, it was thoroughly tested by the Green Section staff and Frank Thomas, Technical Director of the USGA. Putting green speeds throughout the United States were measured under all kinds of conditions. Measurements were made at championship sites as well. From all these measurements, general ranges for putting green speed were determined and published as part of the instruction manual with each Stimpmeter.

Unfortunately, most club members never see the Stimpmeter Instruction Manual. What they know about putting green speed is what they learn during telecasts of the U.S. Open and Masters Tournament. Speeds at these events generally are in excess of 10 feet. Also, not pointed out during television coverage is that the course hosting such

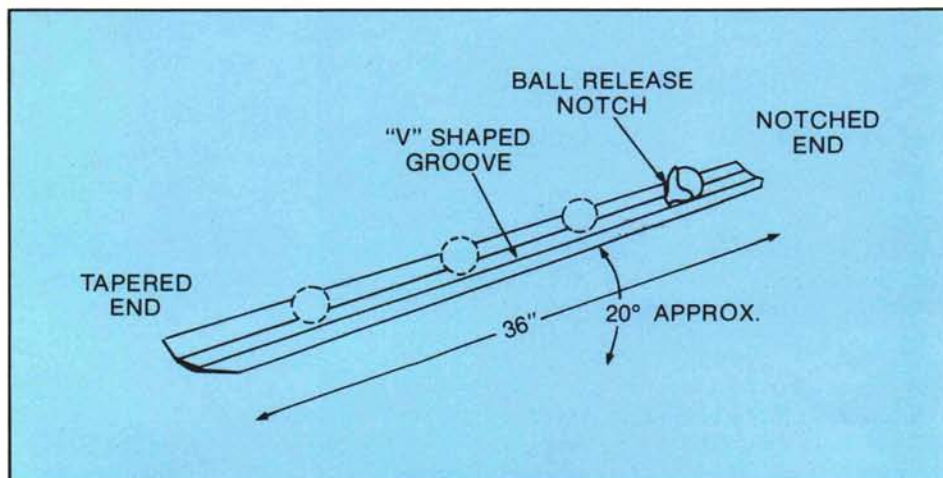

events has worked very carefully over a period of several years to have the golf course in the very best condition. These are courses with higher than average maintenance budgets peaking their greens at incredibly fast speeds for a one-week period.

But it should be pointed out that quality of putting greens is not measured by speed alone. Perhaps as important as speed is consistency from green to green. The Stimpmeter is a tool that can gauge consistency, just as a height of

cut bar gauges mowing height. Smoothness and lack of grain are important factors in putting quality and are just as important on fast greens as on medium-fast greens. The speed at which greens are to be maintained should be a membership decision. If the membership wants fast greens, then they must be willing to provide budgetary support to reach this goal.

TO ACHIEVE fast greens on a daily basis requires more maintenance. Fast greens must be mowed more frequently. They must be verticut more frequently. They must be topdressed more frequently. Fertilization must be on a light and frequent basis. Watering must be done more carefully. Lower mowing heights needed to achieve fast greens also place the turfgrass plant under more stress. A reduced rooting depth can be expected under lower mowing heights. The shorter roots require more frequent irrigation and syringing during the summer to sustain the turfgrass plant. Shorter roots also reduce the grass plant's ability to recover from insect and disease attack. An increase in insecticide and fungicide use may be needed.

8'6"	Fast
7'6"	Medium-Fast
6'6"	Medium
5'6"	Medium-Slow
4'6"	Slow
Speeds for Tournament Play	
10'6"	Fast
9'6"	Medium-Fast
8'6"	Medium
7'6"	Medium-Slow
6'6"	Slow



Superintendent Ray Leyland, New Zealander Ross O'Fee and the Green Section's Don Hoos discuss the Stimpmeter at Industry Hills, California.

To achieve putting green speeds above 8'6" generally requires mowing heights below 3/16 inch. Mowing at these low heights requires additional time by the mechanic adjusting and setting the putting green mowers. Additional grinding and backlapping of bedknives and reels will be needed. Again, pressure is placed on the maintenance budget because of these practices.

Weather conditions also influence putting green speed. Through the year as day length and temperatures change, variations in growth rate occur. If the growth rate is slow, daily mowing and other practices produce faster speeds than if the grass is growing vigorously. In areas of the country subject to high summer temperatures, growth of cool-season grasses almost ceases. Bent-grasses become partially dormant. Maintenance practices that produce fast putting green speeds can be especially dangerous under these conditions. The plant's ability to recover from stress is especially reduced; one mistake could result in turfgrass loss that could require the rest of the season to recover. It is of little value to have fast greens on July 4 if there are no greens in August.

Comparisons between putting green speeds from one club to another are inevitable. Comparing the speed between greens at neighboring clubs has been going on since golf has been

played in this country, and it will continue, with or without the Stimpmeter. However, rather than compare putting green speeds, perhaps the comparison should be in dollars budgeted for putting greens, water, pesticides, and labor. Perhaps a mathematician could develop a formula to compare putting green speed and budget and also add in the weather for good measure. It is the grand total of innumerable agronomic practices that equals good putting qualities. Don't be blinded by speed alone.

THE STIMPETER is a tool, plain and simple. It was invented in the 1930s by Edward S. Stimpson and refined by the USGA Green Section to give the golf course superintendent a way to measure the consistency in putting greens on his course. By using the tool on a regular basis, great inequities in putting green speeds over the course can be detected. If great disparity exists, then maintenance practices can be adjusted to even out the variations.

Many superintendents have found the Stimpmeter to be a valuable tool and have made it work for them to make their courses even better. If you are one of those who consider the Stimpmeter an enemy, I would challenge you to know your enemy. Learn about the Stimpmeter. Educate your member-

ship about its uses and how it works. Make it a tool you can use. Al Radko, former National Director of the Green Section, has suggested the following four-step program for use of the Stimpmeter:

Step 1. Following the steps recommended in the Stimpmeter Instruction Booklet, measure all greens thoroughly and record the average speed of each green. By thorough measurement it is meant that all areas of each putting green be averaged and recorded to determine the overall average of every green, including the practice green. At minimum, three separate areas of each green should be tested and averaged, except where contours or slopes limit the number of measurements per green.

Step 2. If the average speed of any green varies widely from the average speed desired, determine the cause and correct this deficiency to bring the reading up to the desired average speed. This may be done by additional mowing at first and if this does not correct the deficiency, by altering other management practices on deficient greens.

Step 3. Once the average speed is attained and the average speeds are consistent (within plus or minus 6 inches among all greens), then it will only be necessary to test three or four greens daily to insure that the greens remain consistent throughout. The number tested daily will depend on the number of mowers used — i.e., if three different mowers are used, then it will be necessary to test one green mowed by each, etc. If triplex mowers are used, then four greens at minimum should be tested daily (two on the front side and two on the back side).

Step 4. Once every month, re-test all greens to determine whether the average speed continues to be uniformly consistent.

Variations in speed can do more to negate a player's skill than perhaps any other factor on the golf course. Consistency is the key word — not speed. Putting greens kept at speeds over 8'6" as a daily average will need extra labor and manpower because of additional maintenance practices required. Under extreme weather conditions, there is also a much greater potential for turfgrass damage when putting green speeds are maintained above the fast range for regular membership play. As with any other tool, I would urge you to use the Stimpmeter to your professional advantage.